

# 5W Broadband RF Power Amplifier

## Model:EP-AB081

### 1. Product Overview

The **EP-AB081 module** is a high-performance broadband RF power amplifier designed for wireless communication signal enhancement applications.



It supports **100MHz–7200MHz segmented frequency customization**, delivering up to **37dBm (5W) output power** with high efficiency. The module significantly improves signal strength, coverage range, and link stability in RF systems.

### 2. Key Features

- Supports 100MHz–7200MHz segmented frequency customization
- High output power: Up to 37dBm (5W)
- High gain: 35dB  $\pm$ 1dB
- High efficiency: Up to 45%
- Wide input power range: -13dBm to 10dBm
- Compact and lightweight design
- External power control support (3–28V)
- Wide operating temperature range

### 3. Frequency Options

Supports the following standard bands (custom bands available):

- 100 – 1000 MHz
- 1000 – 2000 MHz
- 2000 – 3000 MHz
- 3000 – 4000 MHz
- 4000 – 5000 MHz
- 5000 – 6000 MHz
- 6000 – 7200 MHz

### 4. Electrical Specifications

| Number | Items             | Specifications  |
|--------|-------------------|---|
| 1      | Frequency Range   | 100-1000MHz; 1000-2000MHz; 2000-3000MHz, 3000-4000MHz; 4000-5000MHz; 5000-6000MHz; 6000-7200MHz |
| 2      | Operating Voltage | 22-28V  |

|    |                        |  |
|----|------------------------|--|
| 3  | Gain(S21)              | 35±1dB                                 |
| 4  | Input Return Loss(S11) | ≤-15dB                                 |
| 5  | RF Input Power         | -13~10dBm                              |
| 6  | Output Power           | 37dBm                                  |
| 7  | Current                | 0.45A @24V, 37dBm                      |
| 8  | Efficiency             | 45%@37dBm                              |
| 9  | LED State              | Red                                    |
| 10 | Operating Temperature  | -30℃~85℃                               |
| 11 | Storage Temperature    | -40℃~150℃                              |
| 12 | Operating Humidity     | <95%RH                                 |
| 13 | RF Connector           | Input: SMA-K; Output: SMA-K            |
| 14 | DC Connector           | XT-30 AWG18 20cm red/black wire        |
| 15 | Power Control          | 3-28V 20cm red wire                    |
| 16 | Heat Sink              | 3mm Aluminum                           |
| 17 | PCBA Size              | 69*38*4mm (69*38*7mm if add heat sink) |
| 18 | Net Weight             | 210g                                   |

### Heat Sink Dimensions:

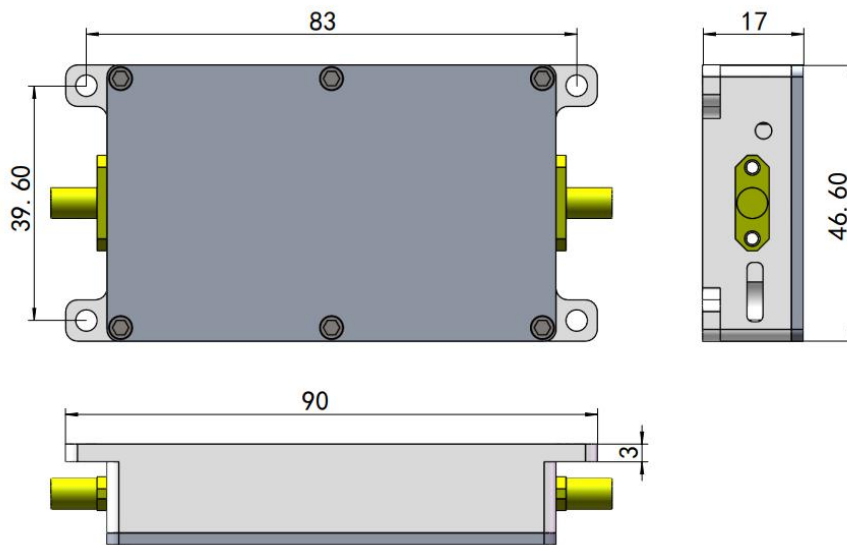

### 5. Applications

- Long-range wireless communication systems

- WiFi 5 / WiFi 6 / WiFi 7 signal enhancement
- RF signal boosting (Sub-7GHz systems)
- Wireless data transmission systems
- Laboratory and RF testing environments

## 6. Performance & Installation Guidelines

Use a 24V /  $\geq 1A$  power supply.

Adequate heat dissipation is required; it is recommended to use a heat sink or cooling fan.

Installation sequence must be followed:

- Screw on the antenna first
- Connect the power supply
- Then connect the RF device

Output power can reach **37dBm** when input power is **3–4dBm** (default gain: **35dB**).

---