

10W Broadband RF Power Amplifier

Model:EP-AB082

1. Product Overview

The EP-AB082 module is a high-power broadband RF amplifier designed for long-range wireless communication and RF signal enhancement applications.



It supports 100MHz – 7200MHz segmented frequency bands with customization support, delivering up to 40dBm (10W) output power with high efficiency and stable performance.

2. Key Features

- Wideband frequency support: 100MHz–7200MHz (segmented)
- High output power: Up to 40dBm (10W)
- High gain: 38dB \pm 1dB
- High efficiency: Up to 45%
- Wide RF input range: -13dBm to 10dBm
- Compact and lightweight module design
- Industrial temperature grade operation

3. Working Frequency

Supports segmented frequency bands (custom bands available):

- 100 – 1000 MHz
- 1000 – 2000 MHz
- 2000 – 3000 MHz
- 3000 – 4000 MHz
- 4000 – 5000 MHz
- 5000 – 6000 MHz
- 6000 – 7200 MHz

4. Electrical Specifications

Number	Items	Specifications
1	Frequency Range	100-1000MHz; 1000-2000MHz; 2000-3000MHz, 3000-4000MHz; 4000-5000MHz; 5000-6000MHz; 6000-7200MHz;
2	Operating Voltage	24-28V
3	Gain(S21)	38 \pm 1dB

4	Input Return Loss(S11)	$\leq -15\text{dB}$
5	RFin Power	-13~10dBm
6	Output Power	40dBm
7	Current	0.8A @28V, 40dBm
8	Efficiency	45%@40dBm
9	LED State	Red
10	Operating Temperature	-30°C ~ 85°C
11	Storage Temperature	-40°C ~ 150°C
12	Operating Humidity	<95%RH
13	RF Connector	Input: SMA-K; Output: SMA-K
14	DC Connector	AWG18 20cm red/black wire
15	Power Control	3-28V 20cm red wire
16	Shell Material	Aluminum
17	Shell Size	90*46*17mm
18	Net Weight	210g

Heat Sink Dimensions:

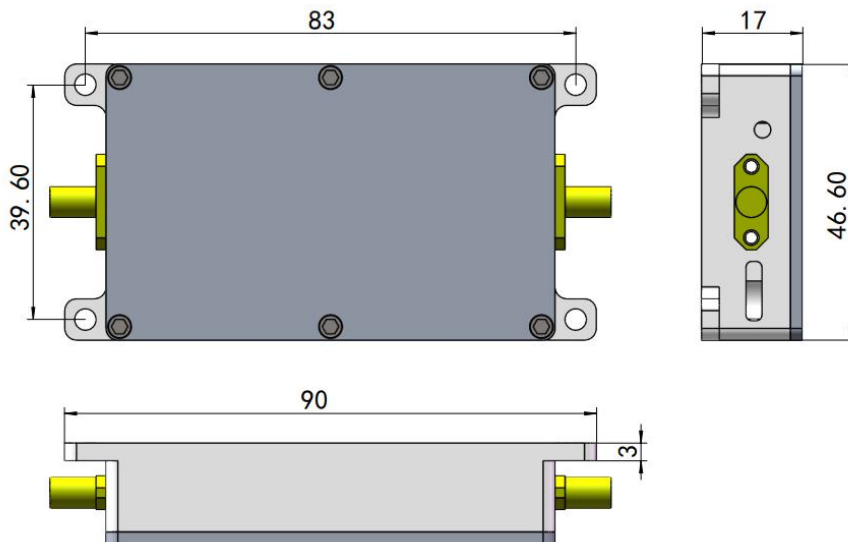

5.Applications

- Wireless communication signal amplification
- WiFi 5 / WiFi 6 / WiFi 7 systems
- RF signal enhancement (Sub-7GHz systems)
- Wireless data transmission systems
- RF laboratory and testing environments

6. Performance & Installation Guidelines

- Output power reaches **40dBm** when input power is **3–4dBm** (default gain: **38dB**)
 - Use a **24–28V / ≥1A regulated power supply** (28V recommended for full output performance)
 - Ensure adequate heat dissipation:
 - Heat sink is required
 - Cooling fan is recommended for continuous operation
 - Installation sequence must be strictly followed:
 1. Connect the antenna first
 2. Then connect the power supply
 3. Finally connect the RF input signal
 - Do **NOT operate without antenna connected**
 - Ensure RF input power remains within the specified range (**-13dBm to 10dBm**)
-