

20W Broadband RF Power Amplifier Module

Model:EP-AB083

1. Product Overview

The EP-AB083 module is a high-power broadband RF amplifier designed for wireless communication and RF signal enhancement applications.

It supports 100MHz – 7200MHz segmented frequency customization, delivering up to 43dBm (20W) output power with high efficiency and stable performance, significantly improving signal coverage and transmission reliability.



2. Key Features

- Supports **100MHz–7200MHz segmented frequency customization**
- High output power: **Up to 43dBm (20W)**
- High gain: **43dB ±1dB**
- High efficiency: **Up to 45%**
- Wide RF input range: **-13dBm to 10dBm**
- Aluminum enclosure for improved thermal performance
- Industrial-grade operating temperature

3. Working Frequency

Supports segmented frequency bands (custom bands available):

- 100 – 1000 MHz
- 1000 – 2000 MHz
- 2000 – 3000 MHz
- 3000 – 4000 MHz
- 4000 – 5000 MHz
- 5000 – 6000 MHz
- 6000 – 7200 MHz

4. Electrical Specifications

Number	Items	Specifications
1	Frequency Range	100-400MHz ; 400-1000MHz; 1000-2000MHz; 2000-3000MHz; 3000-4000MHz; 4000-5000MHz; 5000-6000MHz; 6000-7200MHz;

2	Operating Voltage	24V
3	Gain(S21)	40±1dB
4	Input Return Loss(S11)	≤-15dB
5	RFin Power	-13~10dBm
6	Output Power	43dBm
7	Current	1.8A @24V, 43dBm
8	Efficiency	45%@43dBm
9	LED State	Red
10	Operating Temperature	-30°C ~ 85°C
11	Storage Temperature	-40°C ~ 150°C
12	Operating Humidity	<95%RH
13	RF Connector	Input: SMA-K; Output: SMA-K
14	DC Connector	AWG18 20cm red/black wire
15	Power Control	3-24V 20cm red wire
16	Shell Material	Aluminum
17	Shell Size	132*53*17mm
18	Net Weight	210g

Heat Sink Dimensions:

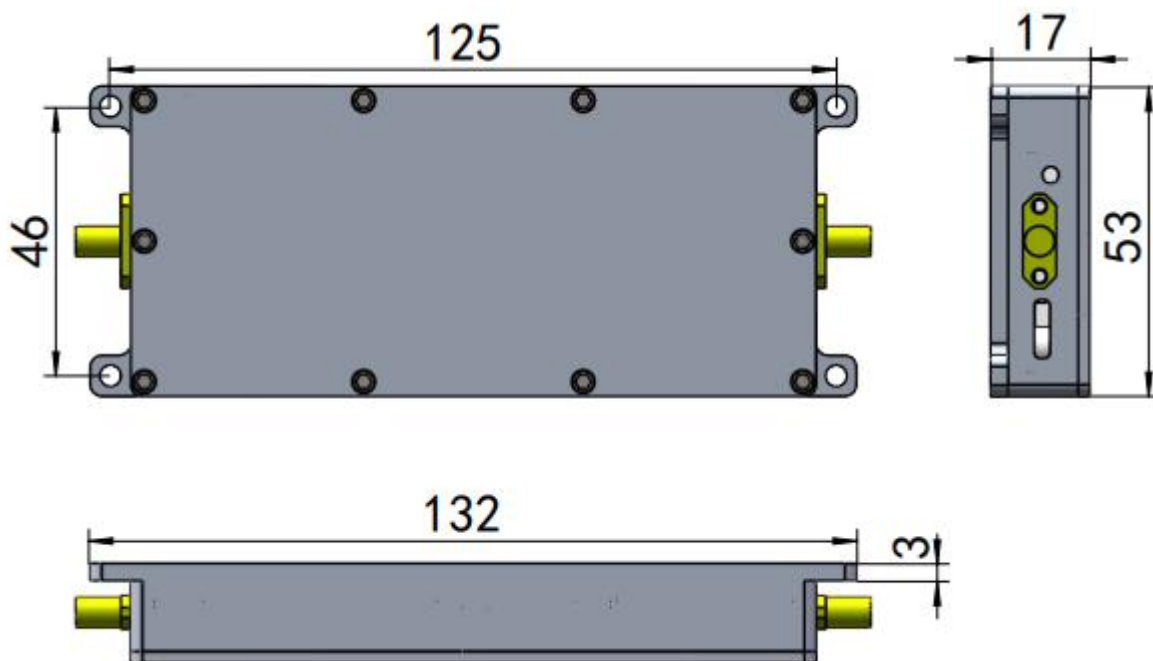

5.Applications

- Wireless communication signal amplification
- WiFi 5 / WiFi 6 / WiFi 7 systems
- RF signal enhancement (Sub-7GHz systems)
- Wireless data transmission systems
- RF testing and laboratory environments

6. Performance & Installation Guidelines

- Output power reaches **43dBm** when input power is **3–4dBm** (default gain: **40dB**)
 - Use a **24V / ≥3A regulated power supply**
 - Ensure adequate heat dissipation:
 1. Aluminum housing provides basic thermal management
 2. External heat sink or cooling fan is **strongly recommended** for continuous or high-load operation
 - Installation sequence must be strictly followed:
 1. Connect the antenna first
 2. Then connect the power supply
 3. Finally connect the RF input signal
 - Do **NOT operate without antenna connected**, as it may cause permanent damage
 - Ensure RF input power remains within the specified range (**-13dBm to 10dBm**)
-