

40W Broadband RF Power Amplifier Module

Model:EP-AB085

1. Product Overview

The EP-AB085 module is a high-power broadband RF amplifier designed for wireless communication and RF signal enhancement applications.

It supports 100MHz – 7200MHz segmented frequency customization, delivering up to 46dBm (40W) output power with high efficiency and stable performance, significantly improving signal coverage, transmission distance, and link reliability.



2. Key Features

- Supports **100MHz–7200MHz segmented frequency customization**
- High output power: **Up to 46dBm (40W)**
- High gain: **40dB ±1dB**
- High efficiency: **Up to 45%**
- Wide RF input range: **-13dBm to 10dBm**
- Aluminum enclosure for enhanced thermal performance
- Industrial-grade operating temperature

3. Working Frequency

Supports segmented frequency bands (custom bands available):

- 100 – 400 MHz
- 400 – 1000 MHz
- 1000 – 2000 MHz
- 2000 – 3000 MHz
- 3000 – 4000 MHz
- 4000 – 5000 MHz
- 5000 – 6000 MHz
- 6000 – 7200 MHz

4. Applications

- Wireless communication signal amplification
 - WiFi 5 / WiFi 6 / WiFi 7 systems
 - RF signal enhancement (Sub-7GHz systems)
 - Wireless data transmission systems
-

- RF testing and laboratory environments

5. Electrical Specifications

Number	Items	Specifications
1	Frequency Range	100-400MHz ; 400-1000MHz; 1000-2000MHz; 2000-3000MHz; 3000-4000MHz; 4000-5000MHz; 5000-6000MHz; 6000-7200MHz;
2	Operating Voltage	28V
3	Gain(S21)	40±1dB
4	Input Return Loss(S11)	≤-15dB
5	RFin Power	-13~10dBm
6	Output Power	46dBm
7	Current	3.2A @28V, 46dBm
8	Efficiency	45%@46dBm
9	LED State	Red
10	Operating Temperature	-30°C~85°C
11	Storage Temperature	-40°C~150°C
12	Operating Humidity	<95%RH
13	RF Connector	Input: SMA-K; Output: SMA-K
14	DC Connector	AWG18 20cm red/black wire
15	Power Control	3-28V 20cm red wire
16	Shell Material	Aluminum
17	Shell Size	132*53*17mm
18	Net Weight	210g

Heat Sink Dimensions:

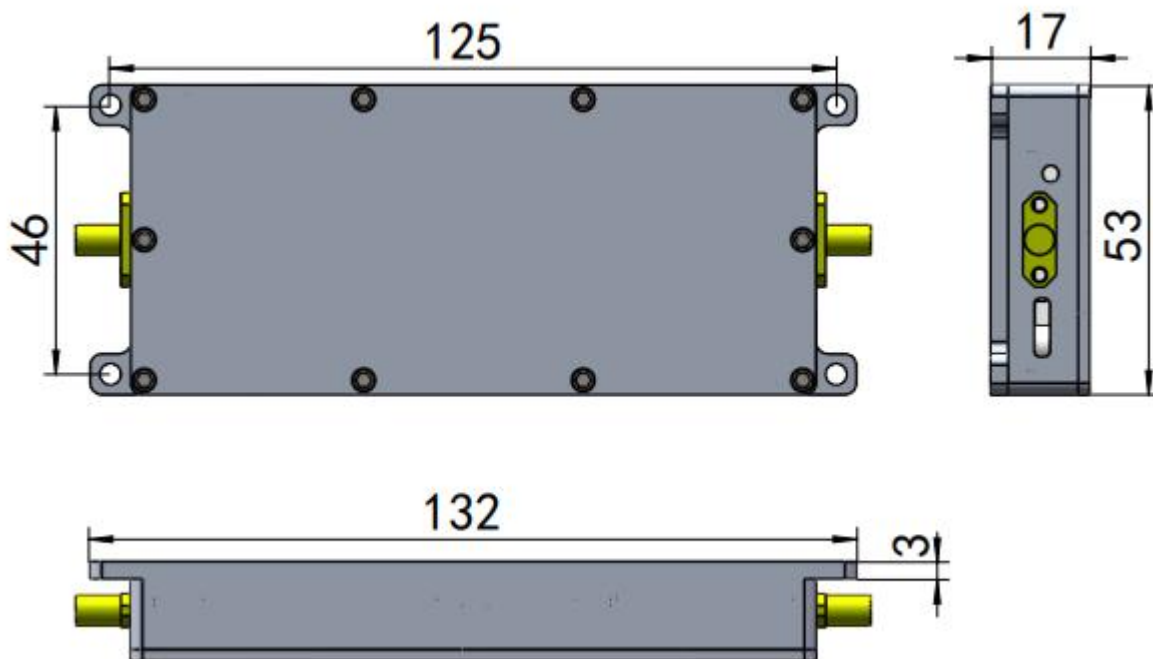

6. Performance & Installation Guidelines

- Output power reaches **46dBm** when input power is **6–8dBm** (default gain: **40dB**)
 - Use a **28V / ≥5A regulated power supply**
 - Ensure sufficient heat dissipation:
 1. Aluminum housing provides basic thermal management
 2. **External heat sink or cooling fan is strongly recommended**, especially for continuous or high-load operation
 - Installation sequence must be strictly followed:
 1. Connect the antenna first
 2. Then connect the power supply
 3. Finally connect the RF input signal

 - Do **NOT operate without antenna connected**, to avoid permanent damage
 - Ensure RF input power remains within **-13dBm to 10dBm**
-